

TruSystem™ 7500 OR Table – New Generation

The new standard for operating system tables – safe, intuitive, ergonomic



With a new generation of operating system tables with interchangeable tabletops, Trumpf Medical's TruSystem™ 7500 ensures safe and comfortable workflow in the operating room. The overall concept of the system table combines a breadth of user-friendly components with specific functions and applications for more safety and reliability. Even more, with the help of the expansion package TruSystem™ 7500 SensorLine OR Table .

An overview of your advantages:

Safe:

- SensorLine technology alerts you when the table or patient is in a compromising position, reducing the risk of tipping or falling, ideal for bariatric patients up to 400 kg (880 lbs)
- The new coupling point gives your staff full visibility of the coupler's locked or unlocked state

Ergonomic:

- Introducing new components that are on average 25% lighter than previous models
- In addition, Trumpf Medical introduced built-in, molded carrying handles on the larger components
- Newly designed motorized transport shuttle for easy and safe patient transport

Intuitive:

- Due to the user-friendly design, margin for error is significantly reduced and misaligned configurations are impossible
- Your focus is on the patient, not the operation of the table

Intelligente Assistenz – TruSystem™ 7500 SensorLine OR Table

The TruSystem™ 7500 OR Table in combination with SensorLine, provides sophisticated solutions for your demands across various applications and configurations.

Extended

Enhancement of the Tilt / Trendelenburg ratio for better access during MIS procedures

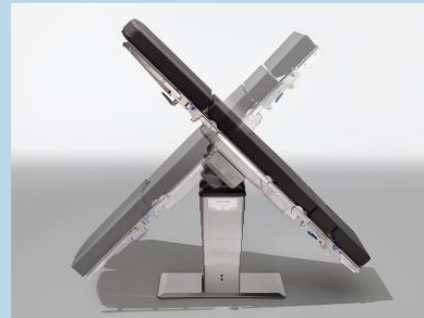

Flexible

Longitudinal slide ranges up to 460 mm (18.1 in) for maximum exposure



Safety

Integrated overload protection and collision detection
improving patient's safety



Precision

Iso center Tilt function and increased speed of adjustment for optimal use in any surgical area





TruSystem™ 7500 OR Table – Overview of the technical specifications

OR table columns	Operating table column, fixed installation	Operating table column, floor setup installation	Operating table column, mobile
Material-No.	1717020/ 1730731 (U)	1717021/ 1730732 (U)	1717023/ 1730720 (U)
Rotation	360° without limitation		
Height	490 mm – 1040 mm (19.29 in – 40.94 in)	520 mm – 1070 mm (20.47 in – 42.13 in)	510 mm – 1060 mm (20.08 in – 41.73 in)
Min. height including universal OR table top	592 mm – 1142 mm (23.31 in – 44.96 in)	622 mm – 1172 mm (24.49 in – 46.14 in)	612 mm – 1162 mm (24.09 in – 45.75 in)
Lift	550 mm (21.65 in)		
Column cross-section	310 mm x 375 mm (12.20 in x 14.76 in)		
Trendelenburg/ Tilt	±45°		
Floor plate height			25 mm (0.98 in)

TruSystem™ 7500 OR Table – Overview of the technical specifications

OR table columns	Operating table column, fixed installation	Operating table column, floor setup installation	Operating table column, mobile	OR table columns	Operating table column, fixed installation
OR tabletops	Universal-operating-tabletops			Special-operating-tabletops	
	U14 H	U24 H	U26 H	ST26 H	Carbon FloatLine
Material-No.	1909799 (V) 1909800 (U) 1947992 (J) 1909811 (W)	1909796 (V) 1909797 (U) 1947989 (J) 1909798 (W)	1909793 (V) 1909794 (U) 1947991 (J) 1909795 (W)	2029417 (V) 2029418 (U) 2029419 (J)	1616204 (V) 1616201 (UV)
Length	832 mm (32.76 in)	1070 mm (42.12 in)	1070 mm (42.12 in)	1004 mm (39.53 in)	2229 mm (87.76 in)
Width across standard rails	600 mm (23.62 in)				520 mm (20.47 in)
Adjustment range, leg section joint	+90° / -105°			±90°	-
Adjustment range, upper back section joint	+90° / -105°				-
Adjustment range, lower back section joint	-	+90° / -55°		+90° / -50°	-
Trendelenburg				±20°	-
Longitudinal slide	460 mm (18.11 in)	400 mm (15.75 in)			800 mm (31.5 in)
Transverse slide	-				±125 mm (4.92 in)
Maximum permissible weight	400 kg (882 lbs)			360 kg (794 lbs)	225 kg (496 lbs)

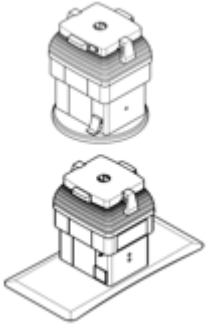
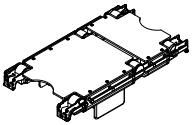
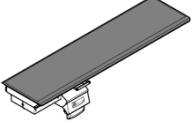
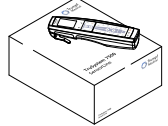
TruSystem™ 7500 OR Table - New Generation

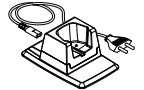
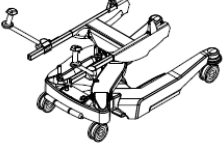
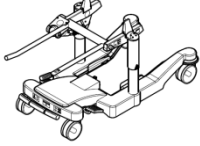
	<p>1717020/ 1730731 1717023/ 1730720 1717021/ 1730732 1854085 1773204 1854086 1854087 1854088</p>	<p>OR table column TruSystem™ 7500 SC/ U OR table column TruSystem™ 7500 MC/ U OR table column TruSystem™ 7500 FC/ U OR table column TruSystem™ 7500 Hybrid (FC) OR table column TruSystem™ 7500 Hybrid (MC) OR table column TruSystem™ m 7500 Hybrid (SC) OR table column TruSystem™ 7500 Hybrid Plus (FC) OR table column TruSystem™ 7500 Hybrid Plus (SC)</p>
	<p>1909793 / 1909794 / 1947991 1909795 1909796 / 1909797 / 1947989 1909798 1909799 / 1909800 / 1947992 1909811</p>	<p>OR table top U26 H V / U / J OR table top U26 H V W OR table top U24 H V / U / J OR table top U24 H V W OR table top U14 H V / U / J OR table top U14 H V W</p>
	<p>2029417/ 2029418/ 2029419</p>	<p>OR table top ST26 H V / U / J</p>
	<p>1616204/ 1616201</p>	<p>OR table top Carbon FloatLine V/ UV</p>
	<p>1997423 1947993 2003863 1633967 2003862 1633968</p>	<p>TruSystem™ 7500 SensorLine Premium OR Table TruSystem™ 7500 SensorLine OR Table Remote control wireless TS™ 7500 Remote control wireless TS™7500 (Hybrid, Hybrid Plus) Cable remote control TS™ 7500 Cable remote control TS™ 7500 (Hybrid, Hybrid Plus)</p>
	<p>1557243 1451204 1537208</p>	<p>Charging unit mobile AC TS7500 Charging unit mounted W/T AC TS7500 Charging unit mounted T DC TS7500</p>
	<p>1774603 1459863 1459862 1489491</p>	<p>Power Shuttle (H) Shuttle 3.7 360 Shuttle 2.7 360 Shuttle 3.6 360</p>
	<p>1418349 1418348 1536993</p>	<p>Shuttle 2.6 360 Shuttle 1.6 360 Cleaning Shuttle 2.01</p>

Overview

➤ Overview hook coupling points U 26H / U 24H	7
➤ Overview hook coupling points U 14H	8
➤ Overview coupling points hooks and fixtures	7
➤ Compatibility	10
➤ Valid statutory and engineer standards	13
➤ Electrical parameters	13
➤ Electrical interfaces	14
➤ Operation conditions	14
➤ Remote control	13
➤ Operation	15
➤ Charging unit for remote control	16
➤ Acoustic signals	16
➤ Adjustments OR table column	17
➤ Adjustments OR table top	17
➤ Dimensions operating table top and operating table column	18
➤ Coupling points operating table top	19
➤ Maximal adjustment range at combination Trendelenburg / Tilt	19
➤ Adjustments Shuttle	20
➤ Dimensions Shuttle	20
➤ Used materials	20
➤ Net weight / loads	21
➤ Cleaning / Disinfection	22
➤ Cleaning in the washing machine	22
➤ Overview operating table column	23
➤ Overview operating table top U14 H	24
➤ Overview operating table top U24 H	24
➤ Overview operating table top U26 H	25
➤ Overview operating table top Carbon FloatLine	25
➤ Overview operating table top ST26 H	26

Overview coupling points U26 H / U24 H / ST26 H

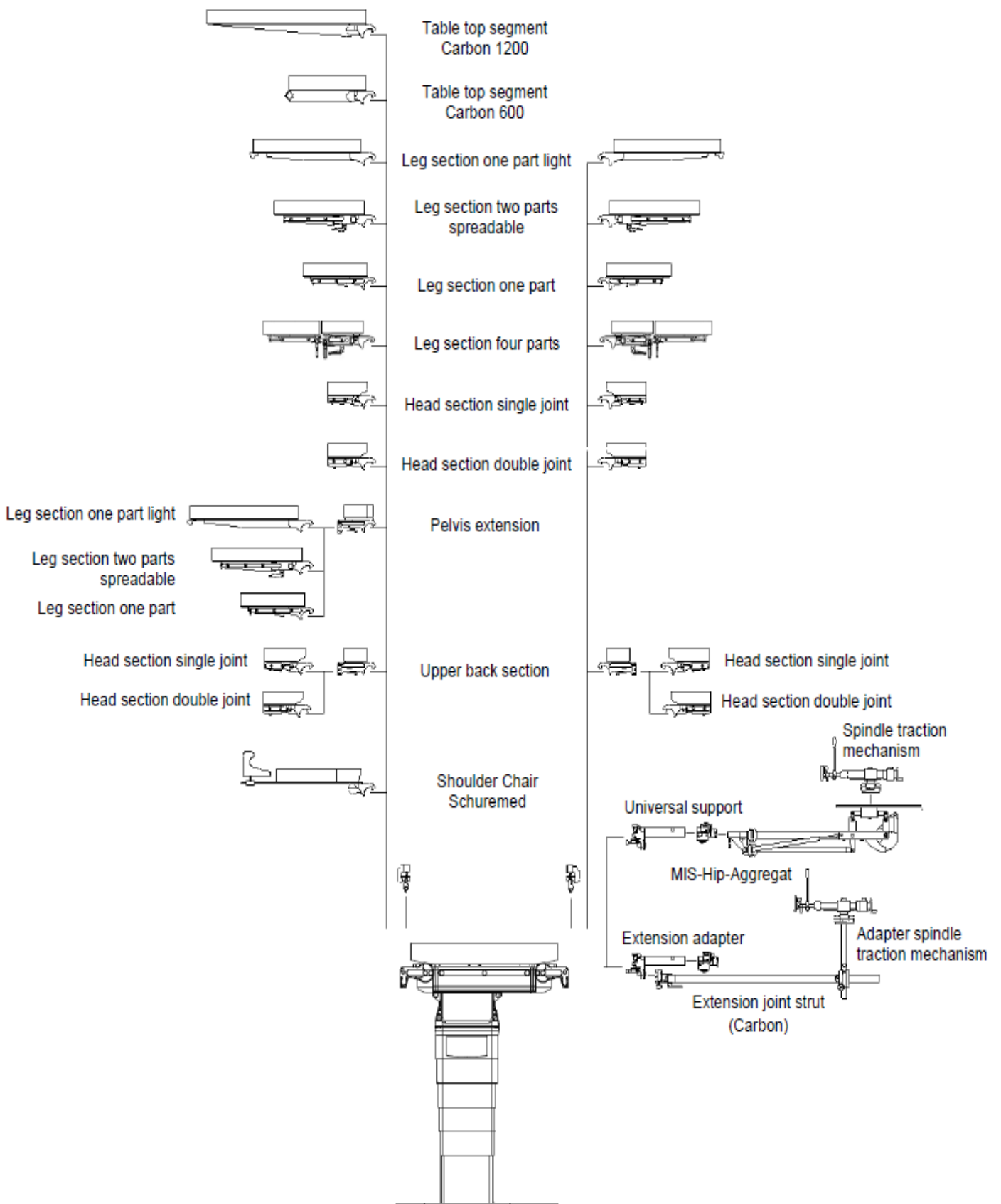



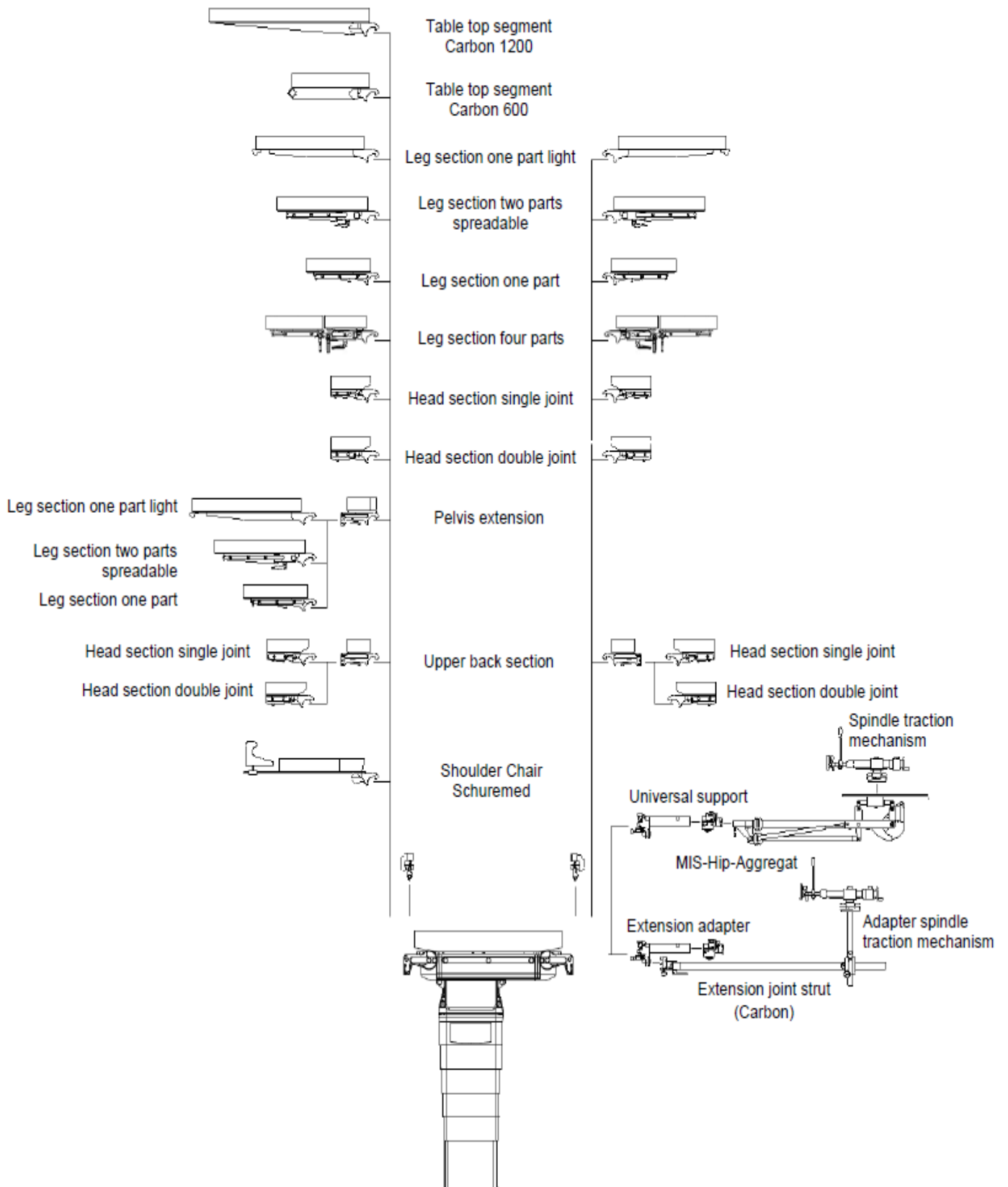

Overview coupling points U14 H

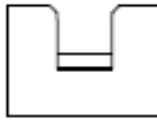

Overview coupling points hook and fixtures

Coupling point for hook and fixtures

Trumpf Medical coupling points have 3 different basic types of hooks and fixtures. The following combinations are possible:

Coupling point	Fixture		
	S	M	L
			
Hook with S encoding 	x	x	x
Hook with M encoding 		x	x
Hook with L encoding 			x

Compatibility

Material-N° *	Name	U14 H		U24 H/ U26 H		ST26 H		Carbon FloatLine	
		HS	FS	HS	FS	HS	FS	HS	FS
1850955	Head section double joint H V	✓	✓	✓	✓	✓	✓		
1853828	Head section double joint H U V	✓	✓	✓	✓	✓	✓		
1850957	Head section double joint H J V	✓	✓	✓	✓	✓	✓		
1850951	Head section single joint H V	✓	✓	✓	✓	✓	✓		
1769761	Head section single joint H U V	✓	✓	✓	✓	✓	✓		
1850953	Head section single joint H J V	✓	✓	✓	✓	✓	✓		
1909812	Upper back section H V	✓	✓	✓	✓	✓	✓		
1909813	Upper back section H V U	✓	✓	✓	✓	✓	✓		
1951368	Upper back section H V J	✓	✓	✓	✓	✓	✓		
1739992	Table top segment Carbon 600 H V	✓	✓	✓	✓	✓	✓		
1850989	Table top segment Carbon 1200 H V	✓	✓	✓	✓	✓	✓		
1909817	Pelvic extension H V	✓	✓		✓		✓		
1951369	Pelvic extension H V J	✓	✓		✓		✓		
1909820	Pelvic extension H V U	✓	✓		✓		✓		
2003449	Swivel segment H V	✓	✓	✓	✓	✓	✓		
1850959	Leg section one part H V	✓	✓	✓	✓	✓	✓		
1739969	Leg section one part H U V	✓	✓	✓	✓	✓	✓		
1850971	Leg section one part H J V	✓	✓	✓	✓	✓	✓		
1850979	Leg section two parts spreadable H V	✓	✓	✓	✓	✓	✓		
1739991	Leg section two parts spreadable H U V	✓	✓	✓	✓	✓	✓		
1850981	Leg section two parts spreadable H J V	✓	✓	✓	✓	✓	✓		
1739993	Leg section one part light H V	✓	✓	✓	✓	✓	✓		

Compatibility

Material-N° *	Name	U14 H		U24 H/ U26 H		ST26 H		Carbon FloatLine	
1789951/ 1789952/ 1789953	Head section basic S/ V/ UV								
1789954/ 1789955/ 1789956	Head section double joint S/ V/ UV								
1789957/ 1789958/ 1789959	Head section COMFORT S/ U/ UV								
1789960/ 1789971/ 1789972	Head section double joint COMFORT S/ U/ UV								
1789973/ 1789974/ 1789975	Head section 530 double joint S/ U/ UV								
1789976/ 1789977/ 1789978	Upper back section S/ V/ UV								
1790002/ 1790003/ 1790004	Table top segment 130 S/ V/ UV								
1790010/ 1790022	Table top segment Carbon three parts V/ UV								
1790006/ 1790007	Table top segment Carbon one part V/ UV								
1790028/ 1790030	Table top segment Carbon 600 U/ UV								
1790037/ 1790038	Table top segment Carbon narrow V/ UV								
1790039/ 1790040	Shoulder basis segment S/ V								
1790061/ 1790062	Shoulder basis segment short S/ V								
1697671/ 1697672	Shoulder support wide S/ V								
1697674/ 1697676	Shoulder support narrow S/ V								

Compatibility

Material-N° *	Name	U14 H		U24 H/ U26 H		ST26 H		Carbon FloatLine	
		HS	FS	HS	FS	HS	FS	HS	FS
1697677/ 1697678	Shoulder support short S/ V								
1549783/ 1549785/ 1549786/ 1549787	Pelvis extension COMFORT/ T/ U/ UT								
1790063/ 1790064/ 1790065	Pelvis extension S/ V/ UV								
1790066/ 1790087/ 1790088	Pelvis extension long S/ V/ UV								
1790025/ 1790026	Table top segment Carbon 450 V/ UV								
1790090/ 1790091/ 1790092	Leg section one part short S/ V/ UV								
1790113/ 1790114	Swivel segment S/ V								
1790093/ 1790094/ 1790095/ 1851975	Leg section two parts short S/ V/ UV/ B								
1790097/ 1790098/ 1790099/ 1851976	Leg section two parts S/ V/ UV/ B								
1790100/ 1790111/ 1790112	Leg section two parts spread joint S/ V/ UV								
1790118	Leg section X-RAY V								
1790119	Leg section X-RAY two parts spread joint V								
1790121	Leg section one part light weight V								
1412708	LegMaster								
1790123/ 1790124	Ophthalmology adapter S/ V								
1567641/ 1567643	Universal support motorized/ T								
1361398/ 1388609	Spinal cord positioning device/ U								
1574666	Extension-adapter	✓			✓		✓		

HS – head side

FS – foot side

Please use the same type of pad or side rail!

Valid statutory and engineer standards

EN 60 601-1	medical electrical equipment, general requirements for safety
EN 60 601-1-2	EMV, class A
EN 60 601-2-46	special requirements for operating table safety
93/42/EEC Appendix IX	class I medical device
MDD Appendix I	meets basic requirements
MDD Appendix VII	perform conformity assessment procedure (CE)

Electrical parameters

External power supply	100-230 V~, 50-60 Hz 240 V~, 50 Hz
Internal power supply	I.P.S., 2 batteries, 40.7 V each 4.7 Ah (SM) I.P.S., 1 battery, 40.7 V each 4.7 Ah (SF)
Operating time with fully charged accumulator (mobile column)	1 day (assumption: 10 surgeries/ day)
Charge time	3 h
Operating mode	continuous operation with intermittent loading (2 min on, 8 min off)
Class of protection	class I, device with internal power supply, I.P.S.
Power consumption	max. 700 VA
Level of protection against electrical shock	type B application part; patient leakage current against electrical shock according to CF as per EN 60601-1
Level of protection against water penetration	IP X4
Level of protection when using flammable mixtures in the area	with battery operation class AP
Heat emission	max. 540 kJ/h / min 44 kJ/h

Electrical interfaces

Connector socket for the control units	on both sides, on column head
Connector socket for the mains cable	only mobile operating table column
Service connector	at column head (USB, Ethernet)
Ethernet	at column head; OR table column SF NET: cable is fixed

Operation conditions

Operating temperature	+ 10°C up to + 40°C (+ 50°F up to 104°F)
Storage temperature	- 20°C up to + 70°C (- 4°F up to 158°F)
Air humidity during operation	20% up to 80%
Air humidity for storage / transport	5% up to 95%
Air pressure	min. 700 mbar up to 1.060 mbar

Remote control

Dimensions including clip (L x W x H)	approx. 230 mm x 70 mm x 55 mm (9.06 in x 2.76 in x 2.17 in)
Weight	approx. 325 g (0.72 lbs)
Display	240 x 320 pixels, color
Power supply	Integrated 3.6 V lithium ion battery (rechargeable with the charger provided)
IR channel / Wireless frequency range	36 kHz / ISM-Band 2.4 GHz
Operating time with fully charged accumulator	During use: 10 h Standby: 5 days active transport lock: 6 months
Charge time	2.5 h

Operation

Operation	cable remote control, wireless remote control, column control, foot switch
Range of wireless remote control	within operating theatre
Remote control function keys	up to 27 functions; in addition to zero position, OFF
Main menu remote display	Status bar; provides current position of OR-table; submenus "menu" and "position"
Functions submenu "menu"	flex, reflex, operation, speed, patient direction, service
Functions submenu service	language selection / operating table selection / shipping lock / recent messages / display HW/SW-status / network address / delete entire position memory / temporary slow traverse / system (secured)
Functions submenu "patient direction"	Changing of the logical patient direction, select "normal" or "invers"
Functions submenu "speed"	Speed function allows you to adjust all electrical adjustments with lower speed (25%, 50%, 75%, 100%)
Functions submenu position	store and recall operating table positions (4 fast storages, 30 overall)
Functions submenu flex / reflex	recall flex or reflex position
Column control functions	up to 19 functions; in addition to zero position, ON/OFF
Indicators of remote control	battery state of remote control (wireless remote control only) / patient direction / zero position / brakes (for fixed installations only) / wireless signal (wireless remote control only)
Indicators of column control	ready for use / emergency operation / head position left/right / malfunction / battery state / battery charging / external power supply / brakes (fixed installations only) / zero position
Foot control	3 functions (combinations of height, Tilt, angle, leg section, back section are possible)
Priority controls	1st column control / 2nd cable remote control / 3rd foot switch / 4th wireless remote control

Charging unit for remote control

Dimensions including clip (L x W x H)	approx. 175 mm x 115 mm x 80 mm (6.89 in x 4.53 in x 3.15 in) (charging unit mobile) approx. 90 mm x 95 mm x 75 mm (3.54 in x 3.74 in x 2.95 in) (charging units mounted)
Weight	approx. 550 g (1.21 lbs) (charging unit mobile) approx. 500 g (1.10 lbs) (charging units mounted)
Operating Voltage	100...230 V / 24 V
Charging voltage	5 V DC
Frequency	50/60 Hz
Charging current	max. 1 A
Maximum power consumption	110 mA / 530 mA

Acoustic signals

Turning on the operating table	series of ascending tones
Turning off the operating table	series of descending tones
The final position of the selected adjustment range is reached, zero pass-through	single tone
Confirmation of an action, e.g. reaching the zero position, finished transfer	double tone
Column batteries require recharging	series of 2 pulsating tones, repeating periodically (at an interval of every few minutes)
Warning or error	three high-pitched tones

Adjustments OR table column

Height without table top	490 mm – 1.040 mm (19.29 in – 40.94 in) (SF, Hybrid SC) 510 mm – 1.060 mm (20.08 in – 41.73 in) (SM, Hybrid MC) 520 mm – 1.070 mm (20.47 in – 42.13 in) (SB, Hybrid FC)
min. height incl. Universal table top H	592 mm (23.31 in) (SC) 612 mm (24.09 in) (MC) 622 mm (24.49 in) (FC)
Lift	400 mm (15.75 in), speed: max. 27 mm/s (1.06 in/s)
Additional lift	150 mm (5.91 in), speed: max. 4,27 mm/s (0.17 in/s)
Tilt	± 30° (speed: max. 1,1°/s)
Trendelenburg / Reverse-Trendelenburg	± 45° (speed: max. 1,7°/s); up to 3°/s with SensorLine
Column rotation	360° freely rotatable (SF and SB), 350° rotatable (hybrid-columns)
Zero position	automatic

Adjustments OR table top

Longitudinal shift	460 mm (18.11 in) (U14 H V), speed: max. 26 mm/s (1.02 in/s) 400mm (15.75 in) (U24 H V / U26 H V), speed: max. 26 mm/s (1.02 in/s) 400 mm (ST26 H V) (15.75 in) speed: max. 26 mm/s (1.02 in/s) 800 mm (31.5 in) (Carbon FloatLine), speed: max. 30 mm/s (1.18 in)
Transversal shift	± 125 mm (4.92 in) (Carbon FloatLine), speed: max. 30 mm/s (1.18 in)
Adjustment range lower back section joint	+ 90° / -105° (U14 H V) (speed: max. 8,4°/s) + 90° / -55° (U24 H V) (speed: max. 8,4°/s) + 90° / -55° (U26 H V) (speed: max. 8,4°/s) + 90° / -50° (ST26 H V) (speed: max. 6,5°/s)
Adjustment range upper back section joint	+ 90° / -105° (U26 H V) (speed: max. 8,4°/s) + 90° / - 105° (U24 H V) (manual) + 90° / - 105° (ST26 H V) (speed: max. 8,4°/s)
Adjustment range leg section joint	+ 90° / - 105° (U26 H V / U24 H V / U14 H V) (speed: max. 8,4°/s) + 90° / - 105° (ST26 H V) (speed: max. 6,5°/s)
Trendelenburg	± 20° (ST26) (speed: max. 1°/s)

Dimensions operating table top and operating table column

Height adjustment OR table column incl. OR table top	<p>592 mm – 1142 mm (23.31 in – 44.96 in) (SC with U14 H V / U24 H V / U26 H V) 612 mm – 1162 mm (24.09 in – 45.75 in) (MC with U14 H V / U24 H V / U26 H V) 622 mm – 1172 mm (24.49 in – 46.14 in) (FC with U14 H V / U24 H V / U26 H V) 666 mm – 1216 mm (26.22 in – 47.87in) (MC with ST26 H) 686 mm – 1236 mm (27.00 in – 48.66 in) (SC with ST26 H) 696 mm – 1246 mm (27.40 in – 49.05 in) (FC with ST26 H) 699 mm – 1249 mm (27.52 in – 49.17 in) (MC with Carbon FloatLine) 679 mm – 1229 mm (26.73 in – 48.39 in) (SC with Carbon FloatLine) 709 mm – 1259 mm (27.91 in – 49.57 in) (FC with Carbon FloatLine)</p>
Column cross section (LxW)	<p>310 mm x 375 mm</p>
Dimensions base plate	<p>900 mm x 408 mm x 25 mm (35.43 in x 16.06 in x 0.98 in) (MC) Ø 430 mm (16.93 in), height 37 mm (1.46 in) (FC) Ø 500 mm (19.69 in) (SC)</p>
Dimensions OR table top without pads (LxWxH)	<p>832 mm x 600 mm x 102 mm (32.76 in x 23.62 in x 4.02 in) (U14 H V) 1070 mm x 600 mm x 102 mm (42.13 in x 23.62 in x 4.02 in) (U24 H V) 1070 mm x 600 mm x 102 mm (42.13 in x 23.62 in x 4.02 in) (U26 H V) 1004 mm x 601 mm x 176 mm (39.53 in x 23.62 in x 6.93 in) (ST26 H) 2290 mm x 520 mm x 189 mm (90.16 in x 20.47 in x 7.44 in) (Carbon FloatLine)</p>
Height of pads	<p>Balanced pad: 90 mm (3.54 in) Comfort Plus pad: 50 mm (1.97 in)</p>
Width of pads	<p>545 mm (U14 H V / U24 H V / U26 H V / ST26 H); 520 mm (Carbon FloatLine)</p>
Dimensions side rails	<p>25 mm x 10 mm (0.98 in x 0.39 in) (EU) 28.6 mm x 9.5 mm (1.13 in x 0.37 in) (US) 32 mm x 10 mm (1.26 in x 0.39 in) (J)</p>

Coupling points operating table top

Table top	Head end	Foot end
U14 H V	Hook coupling point with fixture M (motorized joint)	Hook coupling point with fixture L (motorized joint)
U24 H V	Hook coupling point with fixture M (manual joint)	Hook coupling point with fixture L (motorized joint)
U26 H V	Hook coupling point with fixture M (motorized joint)	Hook coupling point with fixture L (motorized joint)
ST26 H	Hook coupling point with fixture M (motorized joint)	Hook coupling point with fixture L (motorized joint)
Carbon FloatLine	coupling point Carbon 40x40	no coupling point

Maximum adjustment range at combination Trendelenburg / Tilt

Table top U14 H, U24 H, U26 H		Table top ST26 H	
Trendelenburg 45°	No Tilt possible	Trendelenburg 65°	No Tilt possible
Trendelenburg 40°	Tilt 10° possible	Trendelenburg 60°	Tilt 10° possible
Trendelenburg 15°	Tilt 20° possible	Trendelenburg 35°	Tilt 20° possible
Trendelenburg 0°	Tilt 30° possible	Trendelenburg 20°	Tilt 30° possible

Adjustments Shuttle

Lift	230 mm (9.05 in) (3.6/3.7) 210 mm (8.27 in) (Power Shuttle (H)); via pump pedal
Trendelenburg / Reverse-Trendelenburg	15° via quick adjustment (2.7/3.7); via Kurbel (2.6/3.6)
Straight line / 5th wheel	via pedal

Dimensions Shuttle

Length x Width x Height	1520 mm x 750 mm x 780 mm (59.84 in x 29.53 in x 30.71 in) Power Shuttle (H):1552 mm x 750 mm x 760 mm (59.92 in x 29.53 in x 29.92 in)
Wheel type	4 visible dual-swivel wheels (easy to clean)
Wheel diameter	∅ 150 mm (5.91 in)
5th wheel diameter	∅ 100 mm (3.94 in)

Used materials

Tabletop frame, column paneling, coupling points, standard rails, running gear	stainless steel (1.4301); resistant to disinfectant agents, easy to clean
Balanced pad	Viscous elastic pad with dual foam construction, viscous elastic part: 20 mm (0.79 in), High Resilience-foam part: 70 mm (2.76 in), electrically conductive, soft and removable
Standard "PU" pad	polyurethane foam core; electrically conductive, soft and removable
Shuttle	Aluminum AlMgSi1, powder coating, matt paint

Net weight / loads

Net weight OR table column	150 kg (331 lbs) (SF, Hybrid SC) 170 kg (375 lbs) (SM, Hybrid MC) 140 kg (309 lbs) (SB, Hybrid FC)
Net weight OR table top	79 kg (174 lbs) (U14 H V) 85 kg (187 lbs) (U24 H V) 92 kg (203 lbs) (U26 H V) 120 kg (264 lbs) (ST26 H)
Net weight Shuttle	72 kg (159 lbs) (1.6 360) 79 kg (174 lbs) (2.6/2.7 360) 89 kg (196 lbs) (3.6/3.7 360) 125 kg (276 lbs) (Power Shuttle (H))
Maximum load side rails	100 Nm
Maximum load capacity	400 kg (882 lbs) (depends on used operating table top)
Bearing pressure TruSystem™ 7500 SM (Hybrid MC)	1.2 N/mm ² (174.05 psi); max. total load: 7000 N per 0.01 m ²
Bearing pressure TruSystem™ 7500 SF/ SB (Hybrid SC/FC)	0.18 N/mm ² (26.11 psi); max. total load: 7000 N per 0.04 m ²
Bearing pressure Shuttle	approx. 7 N/mm ² (1015.26 psi)

Cleaning / Disinfection

Permitted cleaning agents for stainless steel	all commercially available stainless steel cleaning agents
Permitted cleaning agents for plastic parts / pads	all mildly alkaline all-purpose cleaning agents (active cleaning ingredients: tensides and phosphates)
Cleaning and disinfection agents that are not permitted	do not use any abrasive and corrosive agents containing halogens and peracetic acid and no cleaning and disinfection agents containing alcohol on plastic pieces or pads

Cleaning in washing machine

Conditions	disinfectant to be used: 4500 neodisher Dekonta manufactured by Weigert; rinsing agent: 4307 neodisher BP manufactured by Weigert; total wash time: approx. 8 min
Wash cycle (temperature / water pressure / concentration of disinfection agent / duration / dripping break)	max. 65 °C (149 °F) / approx. 1.5 bar / 0.65 % / approx. 180 s / approx. 90 s
Rinse cycle (temperature / concentration of rinse agent / duration / dripping break)	max. 80 °C (176 °F) / 0.1 % / approx. 120 s / approx. 60 s
Hot air drying cycle (temperature / duration)	max. 80 °C (176 °F) / approx. 300 s
Cooling cycle (duration)	approx. 120 s

Overview operating table column

mobile operating table column

- [1] Column keypad
- [2] Connector socket for the mains cable
- [3] Connecting pin for equipotential bonding conductor
- [4] Connector socket for the control unit (on both sides on the top of the column)
- [5] Endolight
- [6] Holding wedge for operating table top
- [7] Floor plate
- [8] Column head
- [9] Lowest column cover (column base)
- [10] Electrical contact plate for operating table top
- [11] Mains power cable
- [12] Equipotential bonding conductor
- [13] Cover
- [14] Reset button
- [15] Cap
- [16] Ethernet connection socket
- [17] Connector socket for hardware signals

With an operating table top atop it, the mobile operating table column can be moved around on a shuttle and thus positioned anywhere level.

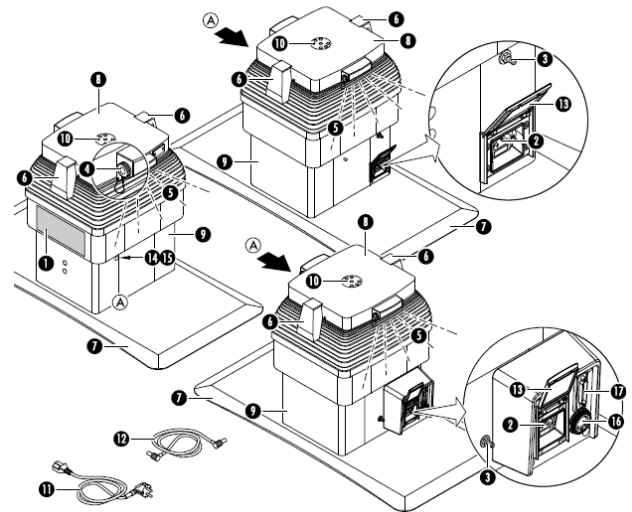

Fixed operating table column installation

- [1] Column keypad
- [4] Connector socket for the control unit (on both sides on the top of the column)
- [5] Endolight
- [6] Holding wedge for operating table top
- [[7] Floor plate
- [8] Column head
- [9] Lowest column cover (column base)
- [10] Electrical contact plate for operating table top
- [14] Reset button
- [15] Cap
- [18] Brake pedal

The operating table column is permanently installed in the operating room and can be rotated smoothly and continuously.

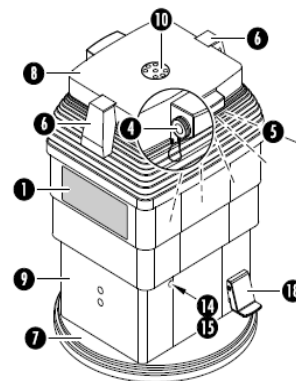

Overview operating table top U14 H V

- [1] Pads
- [2] Seat section
- [3] Side rails for seat section
- [4] Motorized leg section joint with fixture L
- [5] Side rails for leg section joint
- [6] Socket for electrical accessories (e.g. section operating unit) and the connection to an external service tool for maintenance and repair
- [7] Insertion opening for extension adapter
- [8] Bayonet base for extension adapter
- [9] Wedge fixture
- [10] Lower back section ection joint
- [A] Foot enjoint motorized with attachment M
- [15] Crash protection
- [17] Side rail of lower back sd of the operating table top
- [B] Head end of the operating table top

The operating table top U14 H V U is a one-part operating table top with two motorized joint pairs (leg and lower back section) and motorized longitudinal travel.

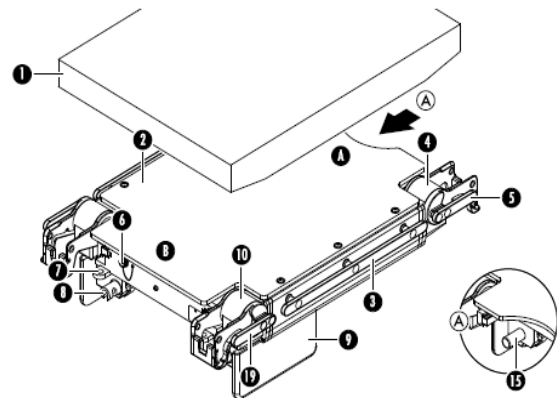

Overview operating table top U24 H V

- [1] Pads
- [2] Seat section
- [3] Side rails for seat section
- [4] Motorized leg section joint with fixture L
- [5] Side rails for leg section joint
- [6] Socket for electrical accessories (e.g. section operating unit) and the connection to an external service tool for maintenance and repair
- [7] Insertion opening for extension adapter
- [8] Bayonet base for extension adapter
- [9] Wedge fixture
- [10] Lower back section joint motorized
- [11] Lower back section
- [12] Side rail of lower back section
- [15] Crash protection
- [16] Attachment M
- [A] Foot end of the operating table top
- [B] Head end of the operating table top

The operating table top U24 H V U is a two-part operating table top with two motorized joint pairs (leg- and back section) and motorized longitudinal travel.

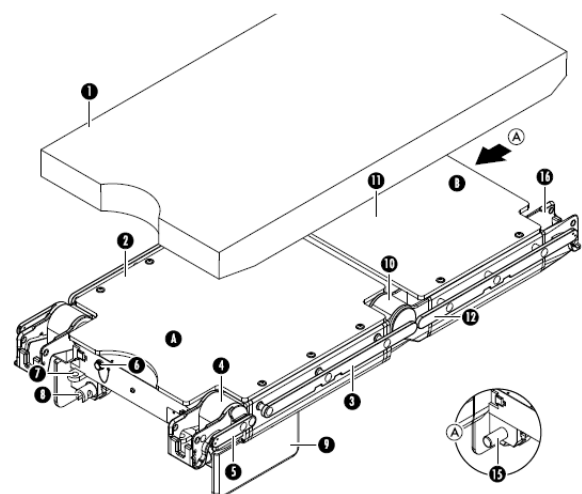

Overview operating table top U26 H V

- [1] Pads
- [2] Seat section
- [3] Side rails for seat section
- [4] Motorized leg section joint with fixture L
- [5] Side rails for leg section joint
- [6] Socket for electrical accessories (e.g. section operating unit) and the connection to an external service tool for maintenance and repair
- [7] Insertion opening for extension adapter
- [8] Bayonet base for extension adapter
- [9] Wedge fixture
- [10] Lower back section joint motorized
- [11] Lower back section
- [12] Side rail of lower back section
- [13] Upper back section joint motorized with attachment M
- [14] Standard rails of upper back section joint
- [15] Crash protection
- [A] Foot end of the operating table top
- [B] Head end of the operating table top

The operating table top U26 H V U is a two-part operating table top with three motorized joint pairs (leg section, lower and upper back section) and motorized longitudinal travel.

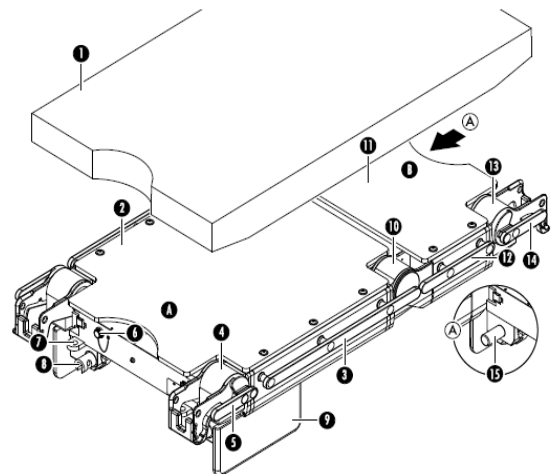

Overview operating table top Carbon FloatLine

- [1] Carbon coupling point 40x40
- [2] Slit for belt attachment
- [3] Connector socket (both sides of the table top) for the Sensor Control FloatLine cable control unit
- [4] Standard rail
- [5] Carbon plate
- [6] Wedge socket (below the cover plate)
- [7] Foot end of the table top
- [8] Head end of the table top
- [9] Rating plate
- [10] Left side of the table top
- [11] right side of the table top
- [A] Foot end of the operating table top
- [B] Head end of the operating table top

The Operating table top Carbon FloatLine is an electromechanically adjustable, one-piece interchangeable table top for TruSystem 7500 operating table system. The patent-supporting surface system of the operating table top is made of carbon fibre.

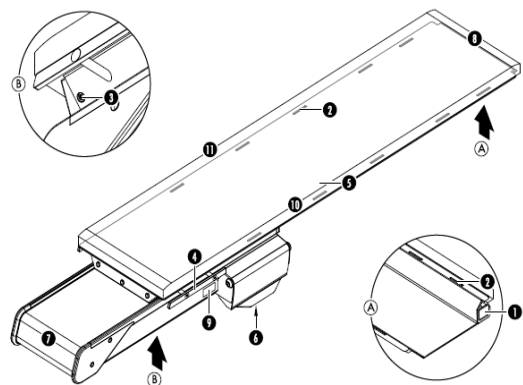

Overview operating table top ST26 H

- [1] Pads
- [2] Seat section
- [3] Side rails for seat section
- [4] Motorized leg section joint with fixture L
- [5] Side rails for leg section joint
- [6] Socket for electrical accessories (e.g. section operating unit) and the connection to an external service tool for maintenance and repair
- [7] Insertion opening for extension adapter
- [8] Bayonet base for extension adapter
- [9] Wedge fixture
- [10] Lower back section joint motorized
- [11] Lower back section
- [12] Side rail of lower back section
- [13] Upper back section joint motorized with attachment M
- [14] Standard rails of upper back section joint
- [15] Crash protection
- [A] Foot end of the operating table top
- [B] Head end of the operating table top

The operating table top ST26 H V U is a two-part operating table top with three motorized joint pairs (leg section, lower and upper back section), motorized longitudinal travel, and (reverse) Trendelenburg adjustment.

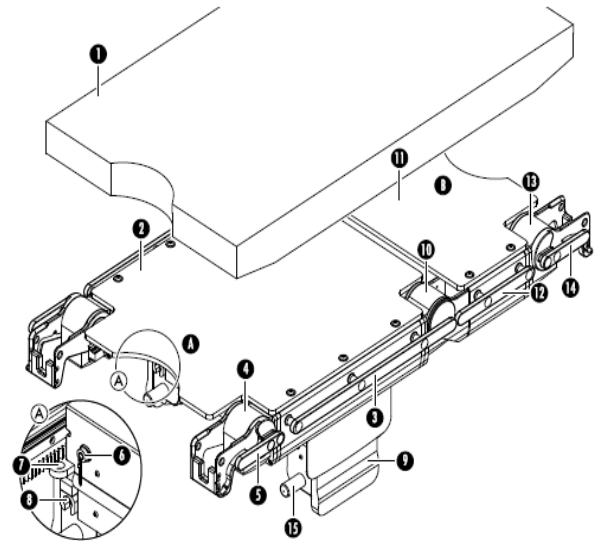

Not all products/ options are available in all countries. For further information about our products or services, please contact your local Trumpf Medical representative or visit our webpage:

www.trumpfmedical.com

TruSystem™ 7500 is a registered trademark of TRUMPF GmbH + Co. KG

Trumpf Medical reserves the right to make changes without notice in design, specifications and models. The only warranty Trumpf Medical makes is the express written warranty extended on the sale or rental of its products. ©2015 TRUMPF Medizin Systeme GmbH + Co. KG, ALL RIGHTS RESERVED.

TRUMPF Medizin Systeme GmbH + Co. KG
Carl-Zeiss-Starße 7-9· 07318 Saalfeld· Telefon +49 (0) 89 80907-0 · E-Mail info@trumpfmedical.com

Flyer ID: 2065986, Date 06/17/2016

Enhancing outcomes for
patients and their caregivers:

Hill-Rom